



# HP4317NdU

Nominal Diameter	12 " / 30 cm
Rated Impedance	8 Ω
Sensitivity	94.5 dB SPL
Power Handling Capacity	500 W AES
SPL max (continuous)	118 dB SPL
Usable frequency range	30 - 1500 Hz
Speaker net mass	5.9 kg

# 12 inches bass driver



## Architecture highlights :

- Noiseless Natural Convection Intercooling System
- Neodymium magnet system with symmetric  $BL(x)$  and  $Le(x)$
- Long excursion suspension with linear behavior for large signal
- High excursion 25.0 mm winding voice coil
- Both sides coated diaphragm (Tropical withstanding)

## Motor architecture

Magnet material	-	Nd
Voice coil diameter	mm	77
Voice coil length	mm	25
Air gap height	mm	10

## Typical characteristics

Rated impedance	Z	W	8
Half space sensitivity (1W@1m)	-	dB SPL	94.5
Usable freq. range	-	Hz	30 - 1500
Power handling capacity (AES)	-	W	500
Max Sound Pressure Level	SPL <sub>max</sub>	dB SPL	118
Min. impedance modulus	Z <sub>min</sub>	W@Hz	6.9@230
Voice-coil inductance @ 1kHz	Le <sub>1k</sub>	mH	1.598
Voice-coil inductance @ 10kHz	Le <sub>10k</sub>	mH	0.740
BL product	BL	N/A	22.0
Moving mass	Mms	kg	0.0931

## Thiele-Small parameters

Resonance frequency	Fs	Hz	43 (±6)
DC Resistance	Re	W	5.4 (±0.5)
Mechanical quality factor	Qms	1	4.62
Electrical quality factor	Qes	1	0.28
Total quality factor	Qts	1	0.27
Suspension compliance	Cms	10 <sup>-6</sup> .m/N	140
Effective piston area	Sd	m <sup>2</sup>	0.0527
Equivalent Cas air load	Vas	m <sup>3</sup>	0.0567
Max linear excursion	Xmax	mm	± 10.0
Linear displacement volume	Vd	10 <sup>-3</sup> .m <sup>3</sup>	0.5269
Reference efficiency	h <sub>0</sub>	%	1.6
Unity load volume	Vas.Qts <sup>2</sup>	10 <sup>-3</sup> .m <sup>3</sup>	4.0

## Absolute maximum ratings

Short term max. input voltage	Vmax	V	125
Max.excursion before damage	Xdam	mm	± 18.0
Ambient operating temperature	Ta	°C	-10 to +50
Storage temperature		°C	-20 to +70
Environmental withstanding			Tropical

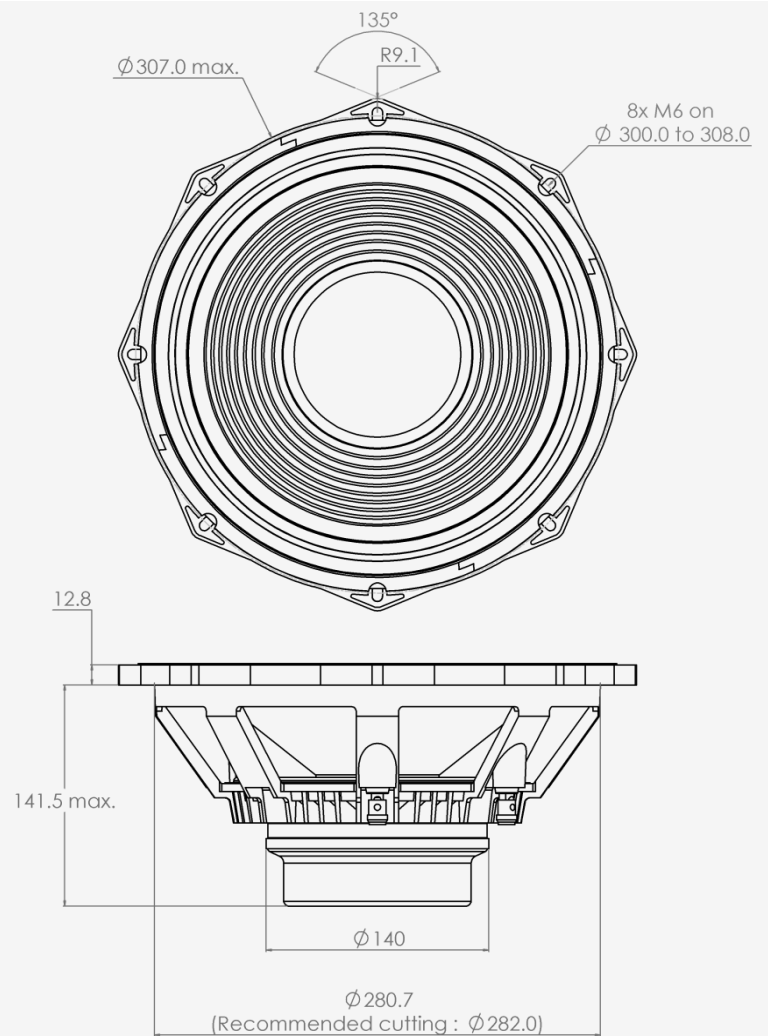

## Mounting information

Air volume occupied by the driver	10 <sup>-3</sup> .m <sup>3</sup>	2.1
Speaker net mass	kg	5.9
Baffle cut-out diameter (front mounting)	mm	282.0
Bolt number & Metric diameter	-	8x M6
Bolt circle diameter	mm	300 to 308
Max overall dimension (on ears)	mm	326.5
Max overall dimension (out of ears)	mm	307.0
Flange height	mm	12.8
Max magnet diameter	mm	140.0
Max depth (front mounting)	mm	141.5
Recommended reflex box	Lts / Hz	-
Electrical connection		Ø4 mm Push buttons



# HP4317NdU

# 12 inches bass driver

SPL curves measured on CEI standard baffle :

- . at 25 cm, normalised 1 m
- . at 1 m for reference
- . Graph amplitude = 60 dB (PHL Audio standard)

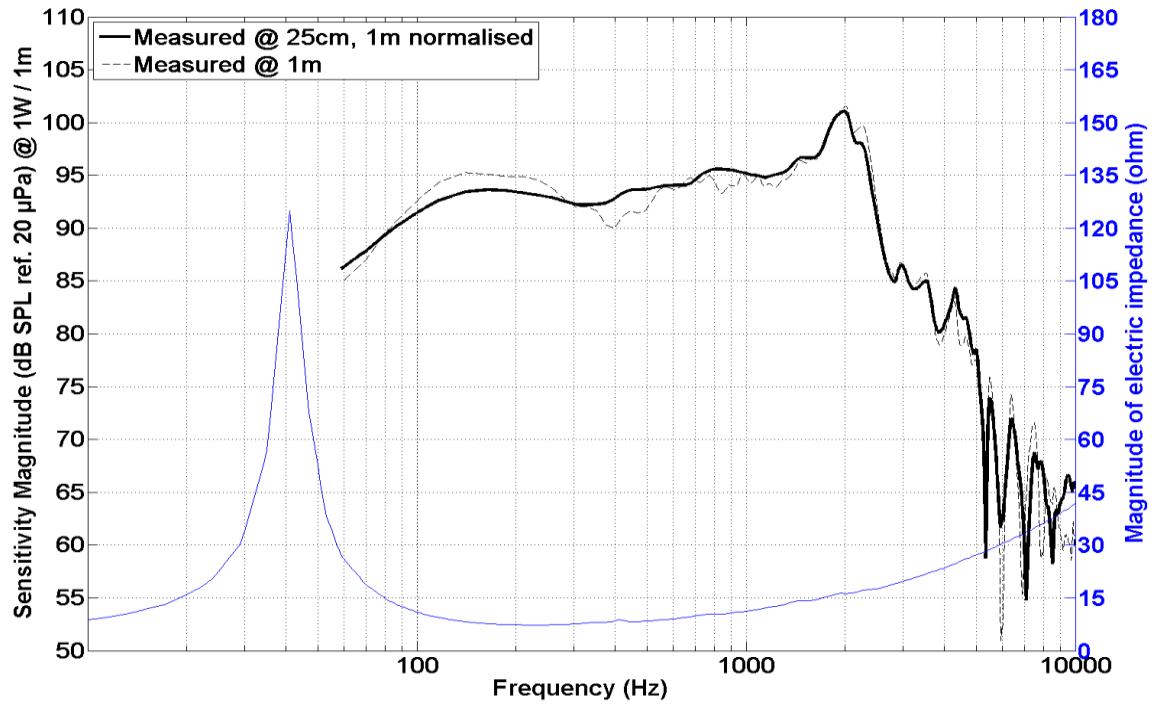

HD curve measured on CEI standard baffle :

- . at 1 meter
- . at power =  $P_{AES} / 4$
- . Graph amplitude 0.01 % to 100 % (PHL Audio standard for  $P_{AES}/4$ )

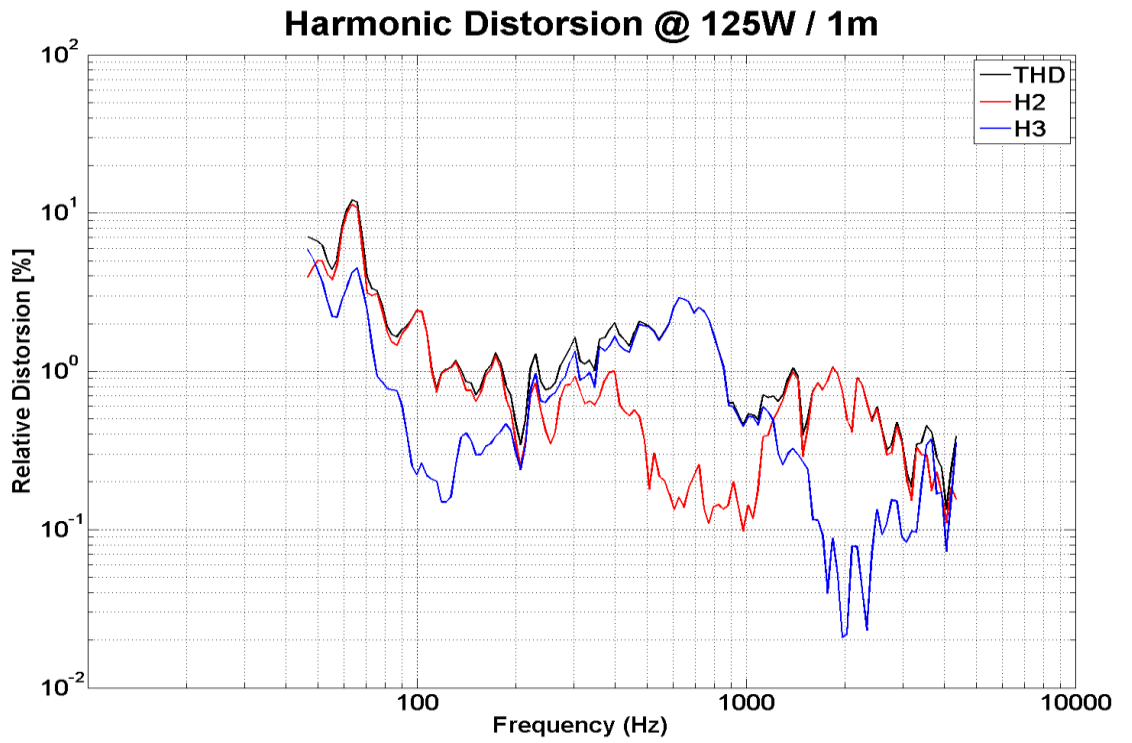

Non linear curves measured thanks to Klippel software and hardware, in free air

